

10 TERMINAL VTM SERIES

NEW

Material: Nylon 6/6
(Natural)

Rating: UL94-VO

10 Terminals: Copper Zinc
60/40 Tin Plate
Nickel Flash

Solderability: Per MIL-STD-202
Method 208

Packaging Tray: TY122x140-A

Application: For vertical mounting of wound toroids from .600 inches to 1.220 in diameter. Coils can be glued onto the cup and the up to 10 terminals are soldered under the mount.. Several smaller toroids can be mounted with diameters oriented in the direction of the B dimension.

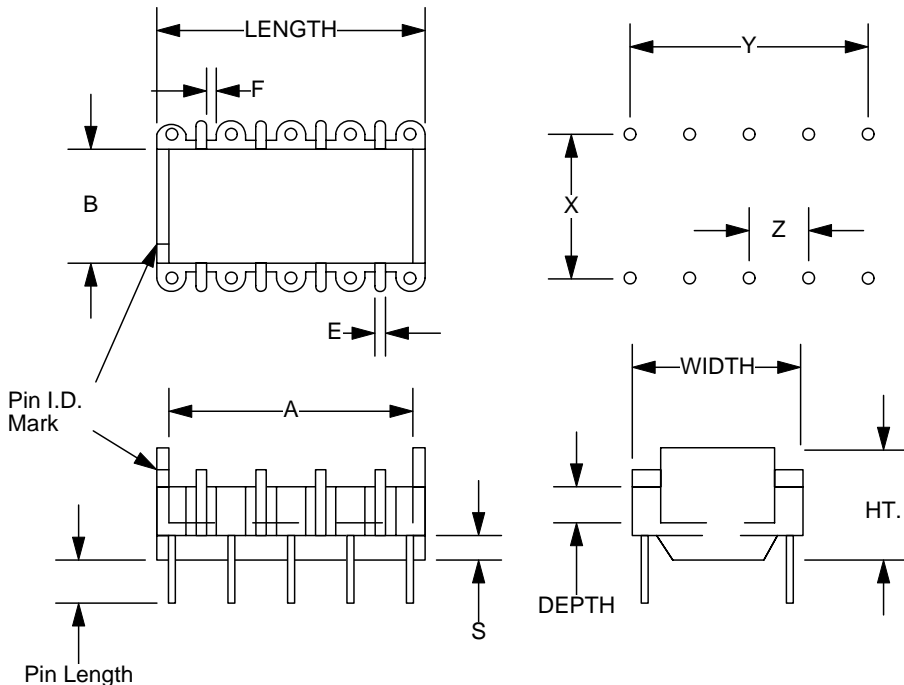

Part No.	Term. Size	Pin Length
VTM880-10	.020x.020 [.50x.50]	.157 [4.0]
VTM1020-10	.027x.027 [.70x.70]	.177 [4.5]
VTM1220-10	.027x.027 [.70x.70]	.177 [4.5]

Part No.	Length	Width	A	B	Ht.	Depth	E	F	X	Y	Z
VTM880-10	.917 [23.3]	.618 [15.7]	.850 [21.6]	.380 [9.65]	.433 [11.0]	.155 [3.9]	.031 [.79]	.031 [.79]	.500 [12.7]	.800 [20.3]	.200 [5.08]
VTM1020-10	1.10 [28.0]	.708 [18.0]	1.00 [25.4]	.467 [11.9]	.472 [12.0]	.148 [3.8]	.055 [1.4]	.040 [1.0]	.590 [15.0]	.984 [25.0]	.246 [6.25]
VTM1220-10	1.30 [33.0]	.906 [23.0]	1.17 [29.7]	.670 [26.4]	.512 [13.0]	.120 [3.1]	.086 [2.2]	.050 [1.3]	.787 [20.0]	1.181 [30.0]	.295 [7.50]